

HOBART701 S Ridge Avenue, Troy, OH 45374
1-888-4HOBART • www.hobartcorp.com**CL64eR advansys
DISHWASHER****HOBART****STANDARD FEATURES**

- Energy recovery
- 342 racks per hour
- Opti-RinSe™ system
- 30 KW electric booster heater
- Rapid return conveyor drive mechanism
- Insulated hinged double doors with door interlock switches
- Door seal system
- Pressure regulating valves
- 19.5 inch chamber height opening
- Top mounted micro-processor control module
- Energy saver mode
- Dirty water indicator
- Low temperature alert
- Conveyor dwell
- Delime notification
- Service diagnostics
- NAFEM Data Protocol compliant
- Computational fluid dynamic designed self-aligning wash manifolds
- Stainless steel debossed anti-clogging wash arms
- Removable integrated pump intake screen
- Stainless steel self-draining pump and impeller
- Single, sloping scrap screen and deep basket
- Stainless panels enclose perimeter and bottom
- Door actuated drain closure
- Single point electrical connection (does not include the booster heater)

DIRECTION OF OPERATION

- Right to Left
- Left to Right

VOLTAGE

- 208/60/3 240/60/3 380/60/3
- 480/60/3 600/60/3

MODEL

- CL64eR – Dishwasher

OPTIONS AT EXTRA COST

- Single point electrical connection, to include electric booster – three phase only
- Higher than standard chamber

ACCESSORIES

- Stainless steel vent hoods (load end only)
- Canopy exhaust power vent kit
- Direct drive unloader
- Side loader
- Blower-dryer
- Drain water tempering kit

Specifications, Details and Dimensions on Inside and Back.



Shown with optional vent hood at load

**CL64eR advansys
DISHWASHER**

CL64eR *advansys* DISHWASHER

HOBART

701 S Ridge Avenue, Troy, OH 45374
1-888-4HOBART • www.hobartcorp.com

THE CL_eR WAREWASHER IS STANDARD WITH THESE EFFICIENT FEATURES . . .

Inside and out the CL_eR warewashers by Hobart are packed with standard components and design innovations that make them the biggest value in the dishwasher industry.



The insulated hinged inspection doors provide easy access in the chamber. Exterior wash pipes and reduced interior baffles reduce clean-up time. The Rapid Return drive allows for a wide separation between the wash and the rinse zone.



The Hobart exclusive microprocessor control module offers a choice of many features, such as an exclusive Energy Saver Mode, Low Temperature Alerts, and Dirty Water Indicator. It also displays pertinent machine status and has a Delime Notification. The controls have built-in Service Diagnostics and are NAFEM Data Protocol Compliant.

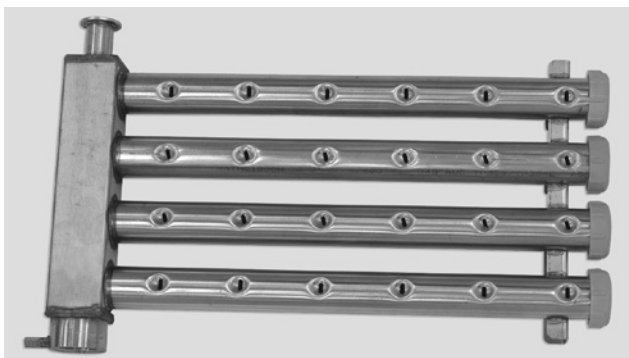

Wash Manifolds. Computational Fluid Dynamic designed wash manifolds are self-aligning and come with Hobart's signature debossed anti-clogging nozzles for superior result.

The Energy Recovery System captures escaping heat and steam from the exhaust air and uses a heat exchanger to recycle it into energy. This free energy is used to preheat the incoming water supply before it enters the booster heater. The ground temperature water passes through a heat exchanger positioned directly in line with the machine's unload exhaust system to capture the energy from the exhaust air and ware leaving the machine to elevate the temperature of the water to 110° before it enters the booster heater.



Opti-RinSe™. Hobart's exclusive Opti-RinSe™ significantly reduces operating cost by reducing rinse water and the energy required to heat the water. The unique spray pattern uses large droplets to more efficiently sanitize the ware.



Built-in Pressureless Stainless Steel Booster Heater. Interwired and interplumbed. Saves on installation and saves floor space. Simplifies operation with just one switch to power dishmachine and booster.



701 S Ridge Avenue, Troy, OH 45374
1-888-4HOBART • www.hobartcorp.com

CL64eR *advansys* DISHWASHER

OTHER STANDARD FEATURES . . .

- **Thermal Layer Curtains** help keep the heat inside the machine.
- **Ball Detent Clutch Conveyor Drive** for maximum protection against conveyor jams
- **Integrated Removable Pump Intake Screen** to offer the ultimate guard of keeping debris from entering the pump.
- **Hinged Door Seals** and stainless steel labyrinth seal for drip-free operation
- **Door Actuated Drain Closure.** Closing the door automatically actuates drain closure, eliminates extra manual steps, ensures that closure is in the correct position.

AVAILABLE OPTIONS AND ACCESSORIES . . .

Flexibility is synonymous with Hobart CLeR dishwashers. If your operation demands a dishwasher with a vent hood, an extended hood . . . a power scrapper, just specify the combination of options that suit your needs.

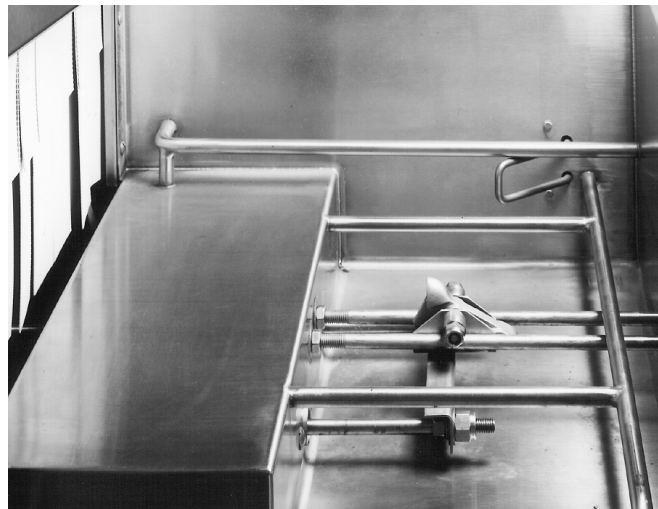

Side Loader. Save up to 20 square feet in the dishroom layout with an optional CLeR Side Loader. Racks are indexed 90° into the dishwasher automatically – a feature that cuts space and reduces labor dramatically. Your dishroom team will appreciate this feature.

OTHER AVAILABLE ACCESSORIES . . .

Blower-dryer, direct drive unloader.

	CL64eR
Machine Ratings (Mechanical)	
Racks per hour (19¾" x 19¾")	342
Conveyor Speed - feet per minute	9.5 max.
Dishes per Hour (Average 25 per rack)	8,550
Glasses per Hour (Average 45 per rack)	15,390
Floor Space – Table to Table (Inches)	64
Overall Dimensions – H x W x D (Inches)	79⅞ x 77¾ x 30¼
Motor H.P.	Wash 2 – Rinse 2
Conveyor Drive H.P.	⅓
Number of Tanks	2
Tank Capacity – Gallons	Wash 23 – Rinse 22
Pump Capacity – Gallons per Minute - Weir Test	Combined 330
Heating Equipment – (For keeping power wash hot) Gas Burners (with Natural Gas)	156,000 BTU per hr. (2 - 78,000)
Electric Heating Unit – Size Used	Regulated 25 KW (15-10)
Booster Heater / Final Rinse	30 KW
Rinse – Minutes operated during hour of maximum operation	60
Final Rinse Flow – Gals. per min. At 20 PSI Flow Pressure	2.2
Final Rinse Flow – Gals. per hr. – MAXIMUM At 15 PSI Flow Pressure	114
At 20 PSI Flow Pressure	132
Rinse 20 PSI Flow Pressure Gal./Rack	Hot Water Sanitizing .39 - 180°F
Steam Consumption – Pounds per hr. - MAXIMUM Approx. 30 lbs. per hr. = 1 boiler H.P. (BHP) Dishwasher, based on 20 PSI steam and on customer supplying final rinse water at 180°F maximum	130
Steam Booster, if used on 20 PSI steam - 20 PSI water flowing - 130°F entering water raised to 180°F min.	63
Exhaust Requirements – Cubic Feet per minute	
Entrance End	200
Discharge End	175
Peak Rate of Drain Flow – Gallons per minute. (Initial rate with full tank)	38
Shipping Weight Crated – Approximate lbs.	970

CL64eR advansys DISHWASHER



701 S Ridge Avenue, Troy, OH 45374
1-888-4HOBART • www.hobartcorp.com

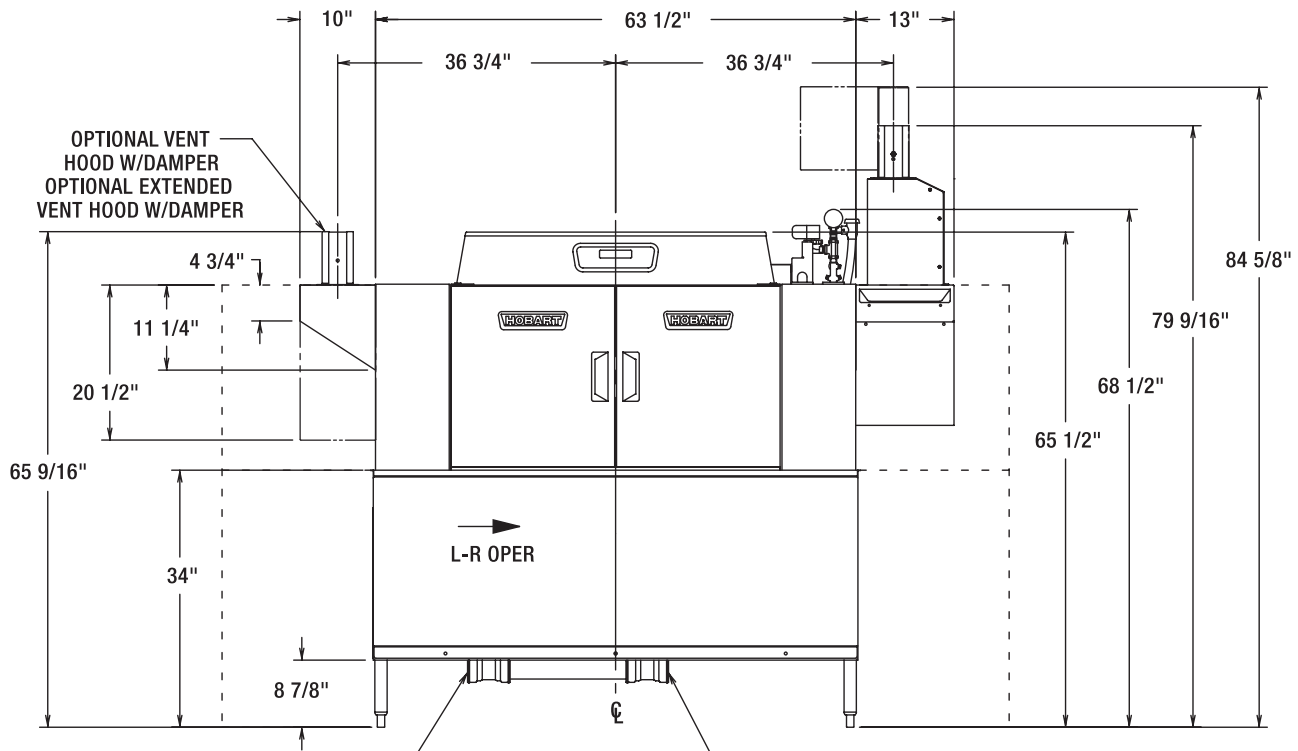

MAY BE DRAINED TO EITHER SIDE OF VALVE, PLUG OPPOSITE SIDE.

WARNING

ELECTRICAL AND GROUNDING CONNECTIONS MUST COMPLY WITH THE APPLICABLE PORTIONS OF THE NATIONAL ELECTRICAL CODE AND/OR OTHER LOCAL ELECTRICAL CODES.

CAUTION: CERTAIN MATERIALS INCLUDING SILVER, ALUMINUM, AND PEWTER ARE ATTACKED BY SODIUM HYPOCHLORITE (LIQUID BLEACH).

ATTN: PLUMBING CONNECTIONS MUST COMPLY WITH APPLICABLE SANITARY, SAFETY, AND PLUMBING CODES.

BOOSTER HEAT 30 KW			
ELEC. SPECS.	RATED AMPS	MINIMUM SUPPLY CIRCUIT CONDUCTOR AMPACITY	MAXIMUM PROTECTIVE DEVICE
200-240/50/3	80.2	90	90
380-415/50/3	53.2	60	60
200/50/3	80.8	90	90
208-240/60/3	80.2	90	90
208/60/3	83.9	90	90
240/60/3	80.2	90	90
380/60/3	42.5	60	60
380-415/60/3	46.4	60	60
480/60/3	40.1	50	50
600/60/3	33.7	40	40

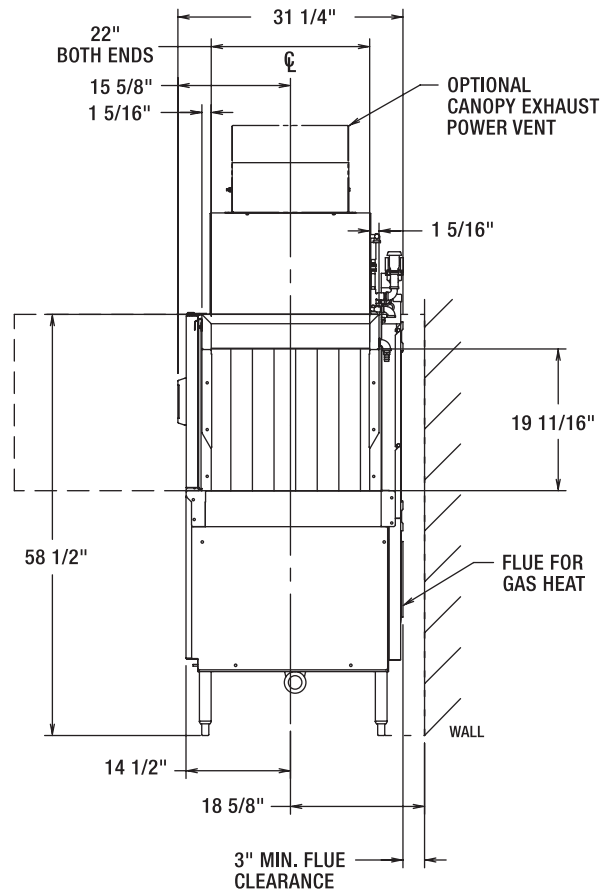



701 S Ridge Avenue, Troy, OH 45374
1-888-4HOBART • www.hobartcorp.com

CL64eR *advansys* DISHWASHER

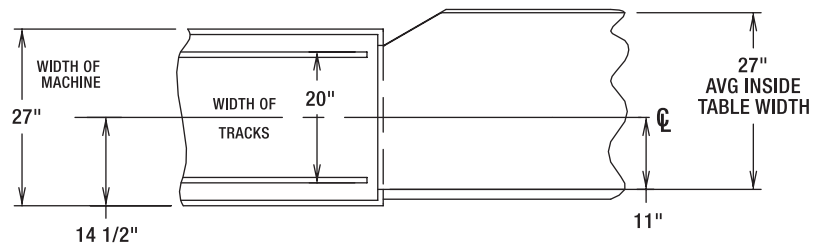
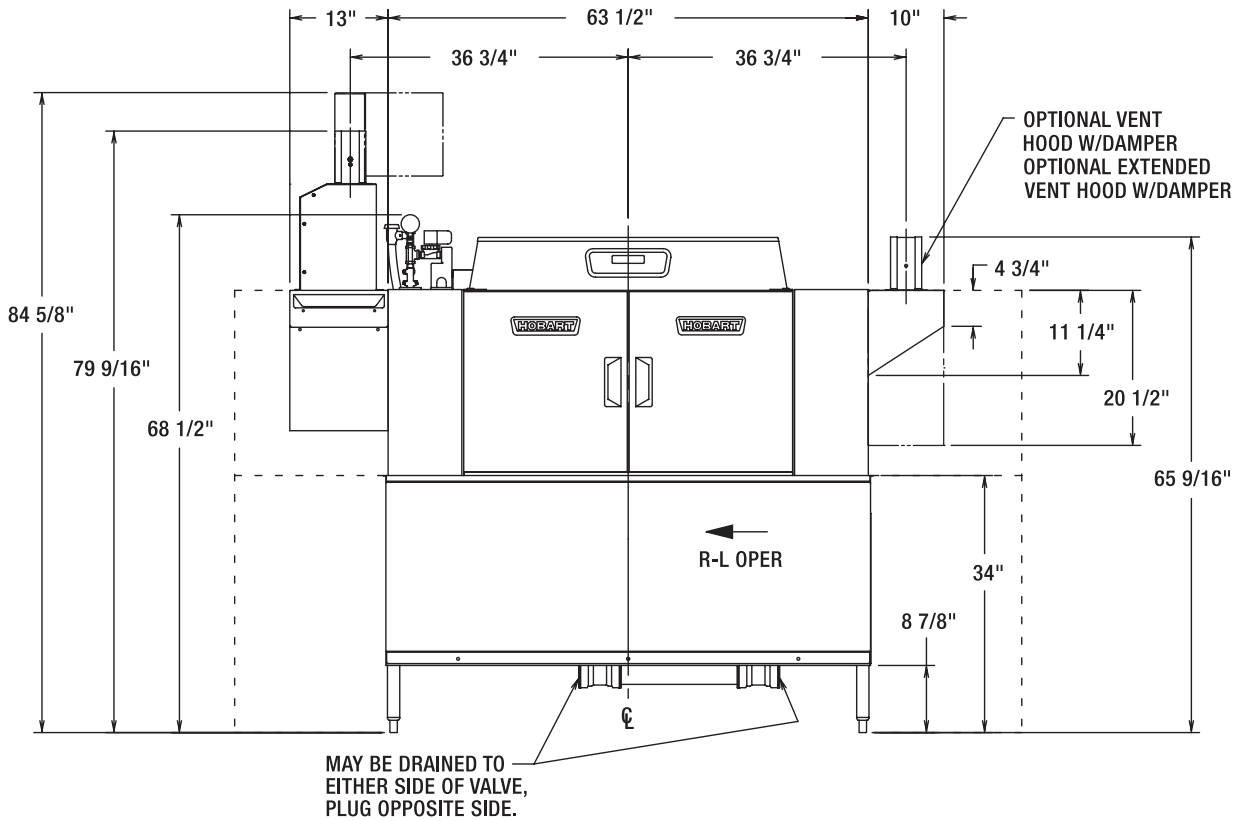

SUGGESTED TRACK AND TABLE LAYOUT

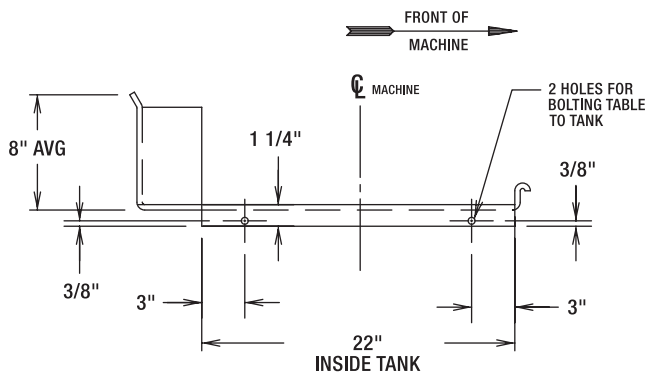

VIEW SHOWING HOLE LOCATIONS IN TURNED DOWN PORTION OF TABLE

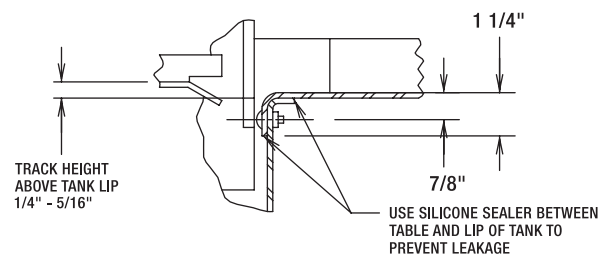

SECTIONAL VIEW SHOWING TABLE CONNECTIONS

CL64eR advansys ELECTRIC L-R



701 S Ridge Avenue, Troy, OH 45374
1-888-4HOBART • www.hobartcorp.com

MODEL: CL64eR
L-R OPERATION
D-941478
REV B

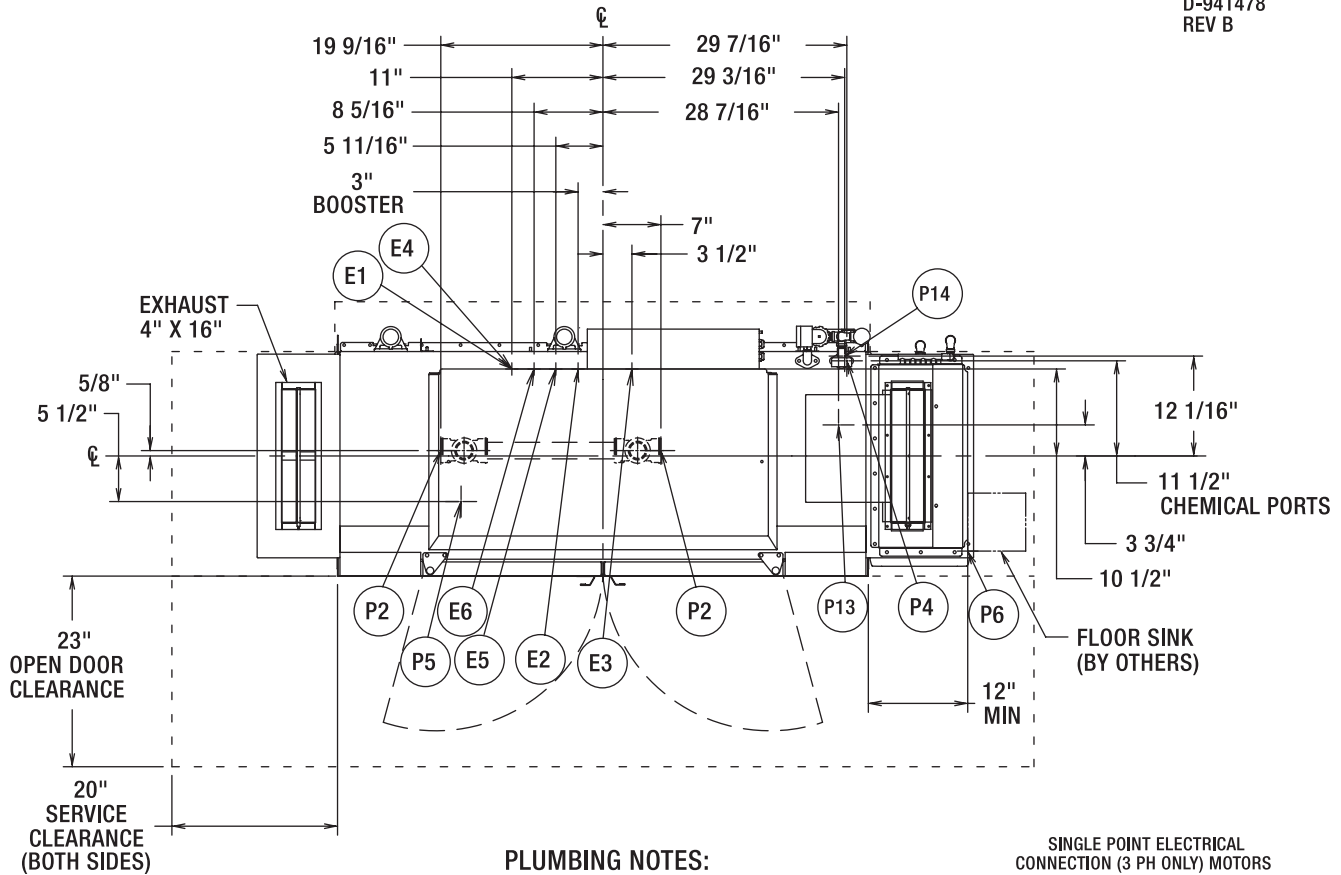

PLUMBING NOTES: ELECTRIC, STEAM, AND GAS HEATS

WATER HAMMER ARRESTOR (MEETING ASSE-1010 STANDARD OR EQUIVALENT) TO BE SUPPLIED (BY OTHERS) IN HOT AND COLD WATER SUPPLY LINES AT SERVICE CONNECTIONS.

RECOMMENDED WATER HARDNESS TO BE 3 GRAINS OR LESS FOR BEST RESULTS.

RECOMMENDED BUILDING FLOWING HOT AND COLD WATER PRESSURE TO THE DISHWASHER IS 20 PSI, (15 PSI MIN - 25 PSI MAX).

IF COLD WATER TEMPERATURE IS LESS THAN 55°F CONTACT SALES ENGINEERING.

FOR CONVENIENCE WHEN CLEANING, WATER TAP SHOULD BE INSTALLED NEAR MACHINE WITH HEAVY DUTY HOSE AND SQUEEZE VALVE.

WHEN USED, CHEMICAL SANITIZING FEEDER MUST BE CERTIFIED TO NSF STANDARD 29.

SINGLE POINT ELECTRICAL CONNECTION (3 PH ONLY) MOTORS AND ELECTRIC TANK HEAT

VOLTAGE	RATED AMPS	MINIMUM SUPPLY CIRCUIT CONDUCTOR AMPACITY	MAXIMUM PROTECTIVE DEVICE
208/60/3	91.5	125	125
240/60/3	90.4	125	125
480/60/3	45.3	60	60
200/50/3	89.7	125	125
380/60/3	49.2	60	60
380-415/50/3	52.0	60	60
600/60/3	32.5	45	45

MISCELLANEOUS NOTES:

OPTIONAL VENT HOOD OR EXTENDED HOOD EXHAUST REQUIREMENTS: 200 CFM ENTRANCE END.

ALL DIMENSIONS TAKEN FROM FLOOR LINE MAY BE INCREASED APPROXIMATELY 3/4" OR DECREASED 1/2".

64" INSIDE TANK (AT TABLE CONNECTION)
63-25/32" TABLE TO TABLE.

NET WEIGHT OF MACHINE: 794 LBS (STD HEIGHT),
DOMESTIC SHIPPING WEIGHT: 970 LBS (STD HEIGHT).
REQUIRES A BACKDRAFT DAMPER IN THE VENTILATION SYSTEM. (TO BE SUPPLIED AND INSTALLED BY OTHERS)

SEPARATE SERVICE CONNECTION FOR MOTORS ON ELEC. HEAT

MOTORS: 1/6 HP CONVEYOR 2 HP WASH			
VOLTAGE	RATED AMPS	MINIMUM SUPPLY CIRCUIT CONDUCTOR AMPACITY	MAXIMUM PROTECTIVE DEVICE
208/60/3	16.5	20	20
240/60/3	15.9	20	20
480/60/3	9.5	15	15
200/50/3	17.5	25	25
380/60/3	11.2	15	15
380-415/50/3	10.6	15	15
600/60/3	8.5	15	15

SEPARATE SERVICE CONNECTION FOR ELEC. HEAT

ELEC. HEAT 15 KW (WASH)			
VOLTAGE	RATED AMPS	MINIMUM SUPPLY CIRCUIT CONDUCTOR AMPACITY	MAXIMUM PROTECTIVE DEVICE
208/60/3	45	60	60
240/60/3	43	60	60
480/60/3	22	30	30
200/50/3	43	60	60
380/60/3	23	30	30
380-415/50/3	29	40	40
600/60/3	14.4	20	20

SEPARATE SERVICE CONNECTION FOR ELEC. HEAT

ELEC. HEAT 10 KW (RINSE)			
VOLTAGE	RATED AMPS	MINIMUM SUPPLY CIRCUIT CONDUCTOR AMPACITY	MAXIMUM PROTECTIVE DEVICE
208/60/3	30	40	40
240/60/3	28.6	40	40
480/60/3	14.3	20	20
200/50/3	28.9	40	40
380/60/3	15.2	20	20
380-415/50/3	16.6	25	25
600/60/3	9.6	15	15



701 S Ridge Avenue, Troy, OH 45374
1-888-4HOBART • www.hobartcorp.com

CL64eR *advansys* ELECTRIC R-L

MODEL: CL64eR
R-L OPERATION
D-941477
REV B

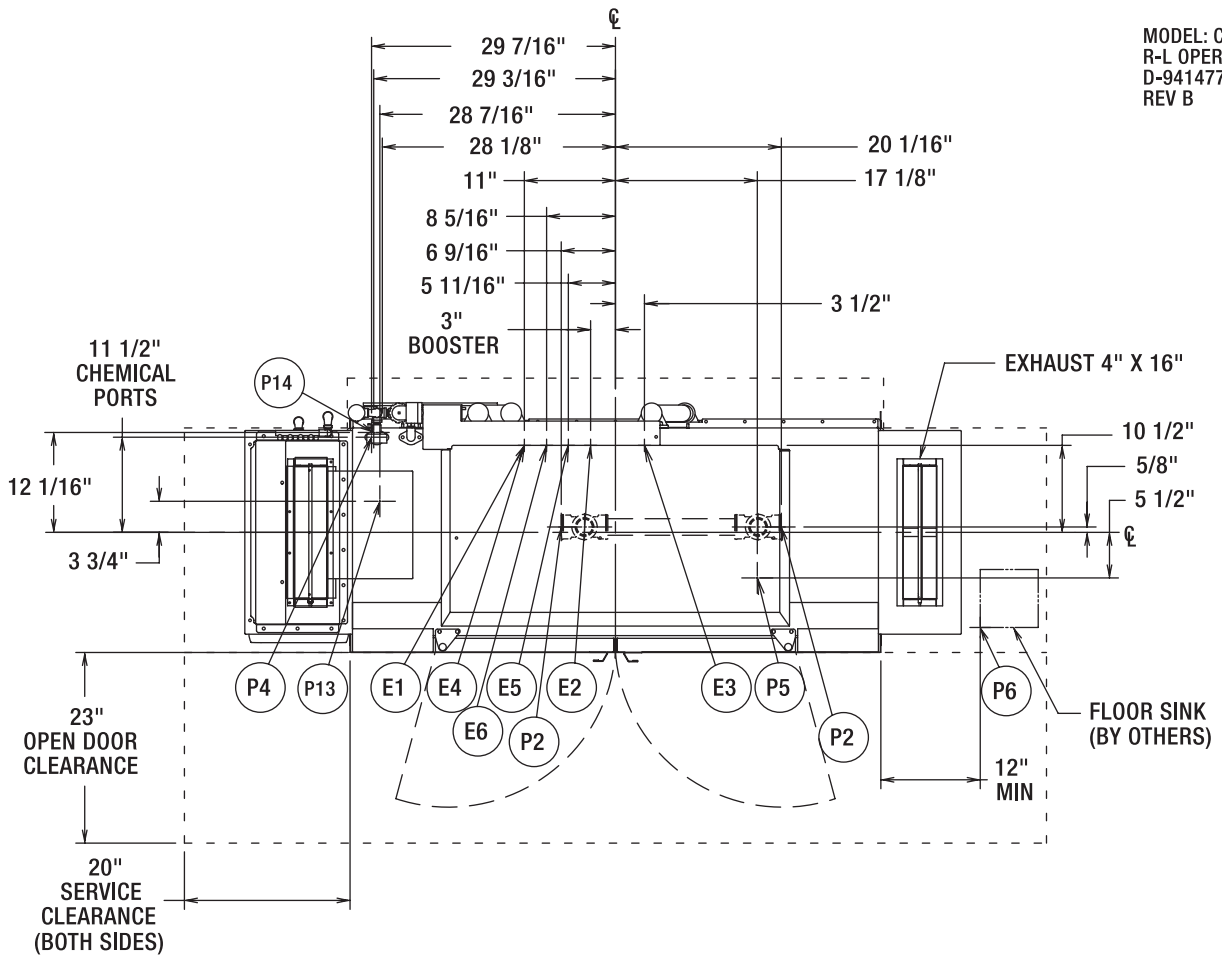

ELECTRICAL CONNECTIONS

CONNECTION INFORMATION
(AFF = ABOVE FINISHED FLOOR)

LEGEND

ELECTRIC, STEAM, AND GAS HEATS

- E1 ELECTRIC CONNECTION: SINGLE POINT, ELEC, GAS, & STEAM, 1-1/4" CONDUIT HOLE OR 2" CONDUIT, 63-3/4" AFF
- E2 ELECTRIC CONNECTION: BOOSTER, 30KW, 1-1/4" CONDUIT HOLE OR 2" CONDUIT HOLE, 63-3/4" AFF
- E3 ELECTRIC CONNECTION: DETERGENT AND RINSE FEEDERS, 1/2" CONDUIT, 64-1/4" AFF

ELECTRIC HEAT ONLY

SINGLE PHASE OR FIELD CONFIGURED 3 PHASE SEPARATE ELECTRIC CONNECTION

- E4 ELECTRIC CONNECTION: MOTORS AND CONTROLS 1-1/4" CONDUIT, 63-3/4" AFF,
- E5 ELECTRIC HEAT: 15,000 WATTS, WASH TANK, 1" CONDUIT HOLE, 63-3/4" AFF.
- E6 ELECTRIC HEAT: 10,000 WATTS, RINSE TANK, 1" CONDUIT HOLE, 63-3/4" AFF.

PLUMBING CONNECTIONS

CONNECTION INFORMATION
(AFF = ABOVE FINISHED FLOOR)

LEGEND

ELECTRIC, STEAM, AND GAS HEATS

- P2 DRAIN: 2" FPT, 7-3/8" AFF TWO POSSIBLE CONNECTIONS; MAY BE DRAINED TO EITHER SIDE OF VALVE, PLUG OPPOSITE SIDE.
- P4 RINSE FEEDER: REMOVE 1/8" NPT PIPE PLUG TO ACCESS TAPPED HOLE, 1/8" NPT 59-9/16" AFF.
- P5 DETERGENT PROBE SENSOR: REMOVE CAP AND STUD ASSEMBLY TO ACCESS 7/8" DIA HOLE (WASH TANK ONLY), 14-5/8" AFF.
- P6 INDIRECT DRAIN-FLOOR SINK: BY OTHERS, 0" AFF. WHEN REQUIRED, INSTALL FLOOR SINK OUTSIDE THE PERIMETER OF THE DISHWASHER.
- P13 HOT WATER CONNECTION: 1/2" FPT, 11-3/16" AFF. HIGH TEMP. W/30K BOOSTER 110°F MIN.
- P14 COLD WATER CONNECTION: 1/2" FPT, 14-3/8" AFF. COLD TEMP. 55°F MIN

CL64eR advansys GAS L-R



701 S Ridge Avenue, Troy, OH 45374
1-888-4HOBART • www.hobartcorp.com

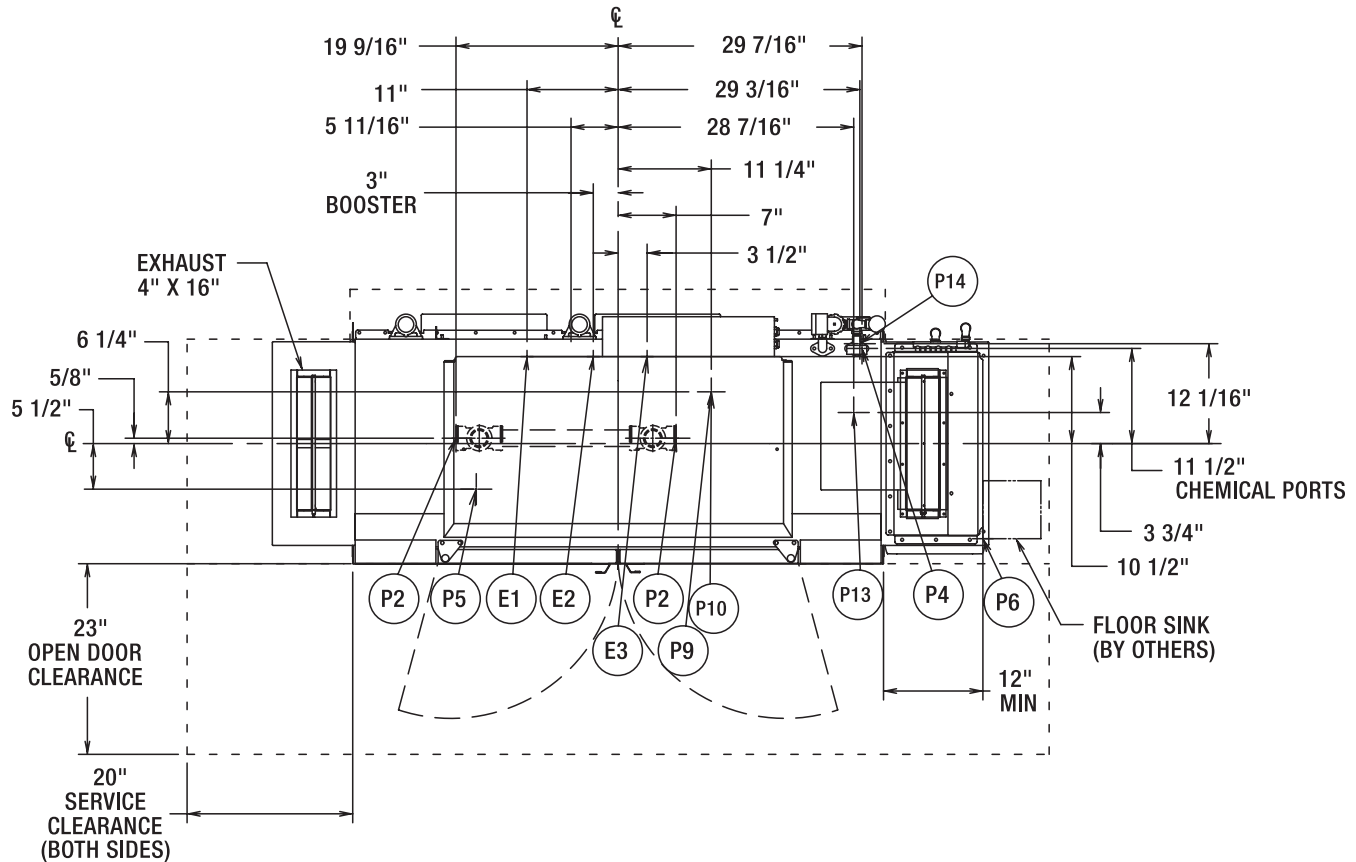

MISCELLANEOUS NOTES:

OPTIONAL VENT HOOD OR EXTENDED HOOD EXHAUST REQUIREMENTS: 200 CFM ENTRANCE END.
ALL DIMENSIONS TAKEN FROM FLOOR LINE MAY BE INCREASED APPROXIMATELY 3/4" OR DECREASED 1/2".
64" INSIDE TANK (AT TABLE CONNECTION)
63-25/32" TABLE TO TABLE.
NET WEIGHT OF MACHINE: 794 LBS (STD HEIGHT), DOMESTIC SHIPPING WEIGHT: 970 LBS (STD HEIGHT).
REQUIRES A BACKDRAFT DAMPER IN THE VENTILATION SYSTEM. (TO BE SUPPLIED AND INSTALLED BY OTHERS)

SERVICE CONNECTION FOR MOTORS AND CONTROLS

MOTORS: 1/6 HP CONVEYOR 2 HP WASH			
VOLTAGE	RATED AMPS	MINIMUM SUPPLY CIRCUIT CONDUCTOR AMPACITY	MAXIMUM PROTECTIVE DEVICE
208-240/60/3	19.4	25	25
380/60/3	12.8	20	20
480/60/3	10.8	15	15
600/60/3	9.5	15	15

PLUMBING NOTES:

ELECTRIC, STEAM, AND GAS HEATS

WATER HAMMER ARRESTOR (MEETING ASSE-1010 STANDARD OR EQUIVALENT) TO BE SUPPLIED (BY OTHERS) IN HOT AND COLD WATER SUPPLY LINES AT SERVICE CONNECTIONS.

RECOMMENDED WATER HARDNESS TO BE 3 GRAINS OR LESS FOR BEST RESULTS.

RECOMMENDED BUILDING FLOWING HOT AND COLD WATER PRESSURE TO THE DISHWASHER IS 20 PSI, (15 PSI MIN - 25 PSI MAX).

IF COLD WATER TEMPERATURE IS LESS THAN 55°F CONTACT SALES ENGINEERING.

FOR CONVENIENCE WHEN CLEANING, WATER TAP SHOULD BE INSTALLED NEAR MACHINE WITH HEAVY DUTY HOSE AND SQUEEZE VALVE.

WHEN USED, CHEMICAL SANITIZING FEEDER MUST BE CERTIFIED TO NSF STANDARD 29.

GAS HEAT ONLY

FOR NATURAL GAS, PRESSURE TO THE BURNER (CUSTOMER CONNECTION) SHOULD BE 3.5" MIN, 7" MAX W.C.

FOR LP GAS, PRESSURE TO THE BURNER (CUSTOMER CONNECTION) SHOULD BE 8" MIN, 11" MAX. W.C.

IF GAS PRESSURE IS HIGHER THAN 7"(NAT) OR 11"(LP) W.C., A PRESSURE REGULATING VALVE MUST BE INSTALLED (BY OTHERS) IN THE GAS LINE TO THE DISHWASHER.

GAS HEAT (NATURAL OR LP) BTU/HR INPUT - 78,000.

GAS EXHAUST VENTING MUST BE INSTALLED ACCORDING TO LOCAL CODE. DO NOT CONNECT FLUE TO POWER VENT. SEE INSTALLATION MANUAL FOR GAS VENTING.



701 S Ridge Avenue, Troy, OH 45374
1-888-4HOBART • www.hobartcorp.com

CL64eR *advansys*
GAS R-L

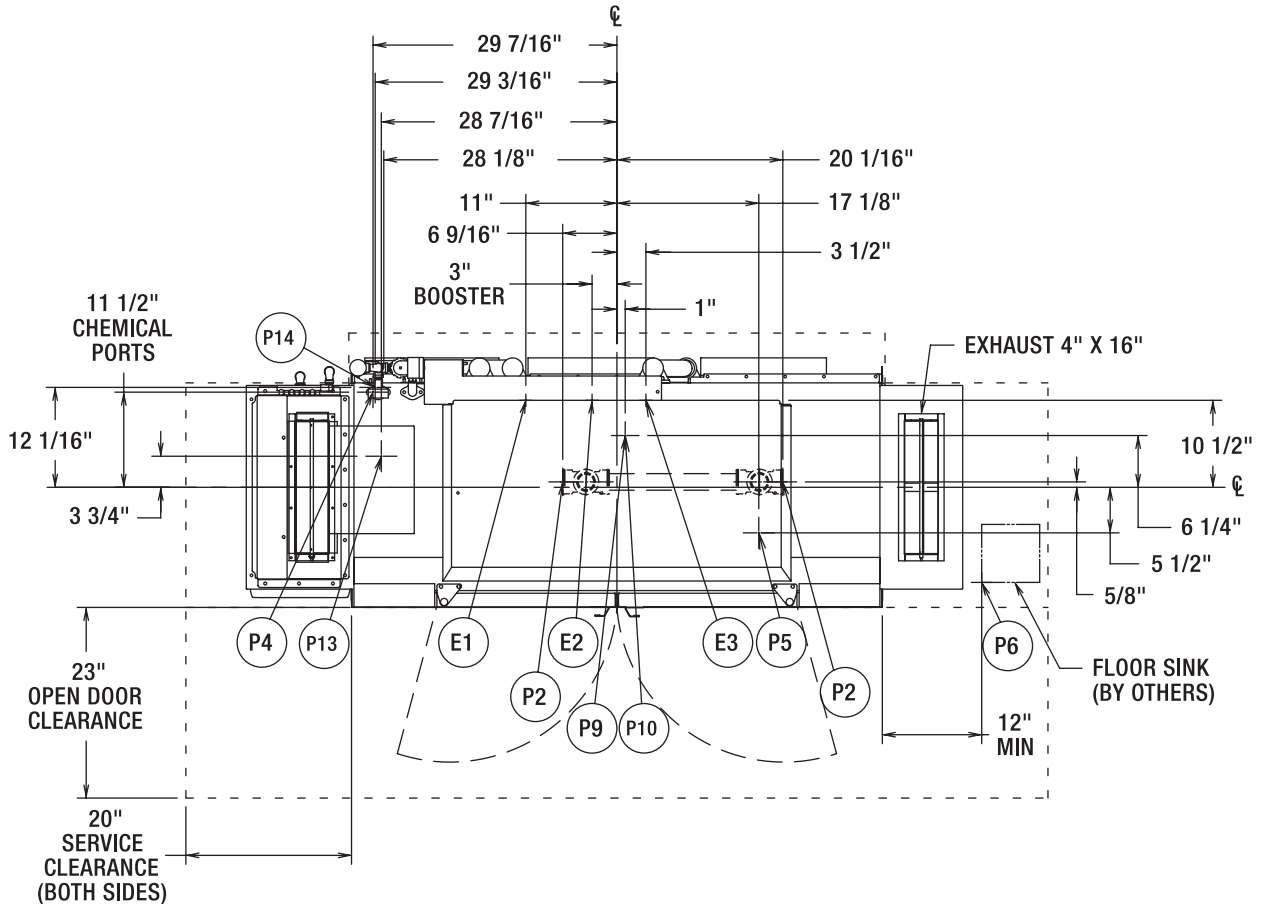

PLUMBING CONNECTIONS
CONNECTION INFORMATION
(AFF = ABOVE FINISHED FLOOR)

LEGEND

ELECTRIC, STEAM, AND GAS HEATS

ELECTRICAL CONNECTIONS

CONNECTION INFORMATION
(AFF = ABOVE FINISHED FLOOR)

LEGEND

ELECTRIC, STEAM, AND GAS HEATS

- E1 ELECTRIC CONNECTION: SINGLE POINT, ELEC, GAS, & STEAM, 1-1/4" CONDUIT HOLE OR 2" CONDUIT, 63-3/4" AFF
- E2 ELECTRIC CONNECTION: BOOSTER, 30KW, 1-1/4" CONDUIT HOLE OR 2" CONDUIT HOLE, 63-3/4" AFF
- E3 ELECTRIC CONNECTION: DETERGENT AND RINSE FEEDERS, 1/2" CONDUIT, 64-1/4" AFF

- P2 DRAIN: 2" FPT, 7-3/8" AFF TWO POSSIBLE CONNECTIONS; MAY BE DRAINED TO EITHER SIDE OF VALVE, PLUG OPPOSITE SIDE.
- P4 RINSE FEEDER: REMOVE 1/8" NPT PIPE PLUG TO ACCESS TAPPED HOLE, 1/8" NPT 59-9/16" AFF.
- P5 DETERGENT PROBE SENSOR: REMOVE CAP AND STUD ASSEMBLY TO ACCESS 7/8" DIA HOLE (WASH TANK ONLY). 14-5/8" AFF.
- P6 INDIRECT DRAIN-FLOOR SINK: BY OTHERS, 0" AFF. WHEN REQUIRED, INSTALL FLOOR SINK OUTSIDE THE PERIMETER OF THE DISHWASHER.
- P13 HOT WATER CONNECTION: 1/2" FPT, 11-3/16" AFF. HIGH TEMP. W/30K BOOSTER 110°F MIN.
- P14 COLD WATER CONNECTION: 1/2" FPT, 14-3/8" AFF. COLD TEMP. 55°F MIN

GAS HEAT ONLY

- P9 GAS CONNECTION - NAT., 3/4" FPT, 8-1/4" AFF; 3.5" MIN, 7" MAX W.C. INCOMING.
- P10 GAS CONNECTION - L.P., 3/4" FPT, 8-1/4" AFF; 8" MIN, 11" MAX W.C. INCOMING.

CL64eR advansys STEAM L-R



701 S Ridge Avenue, Troy, OH 45374
1-888-4HOBART • www.hobartcorp.com

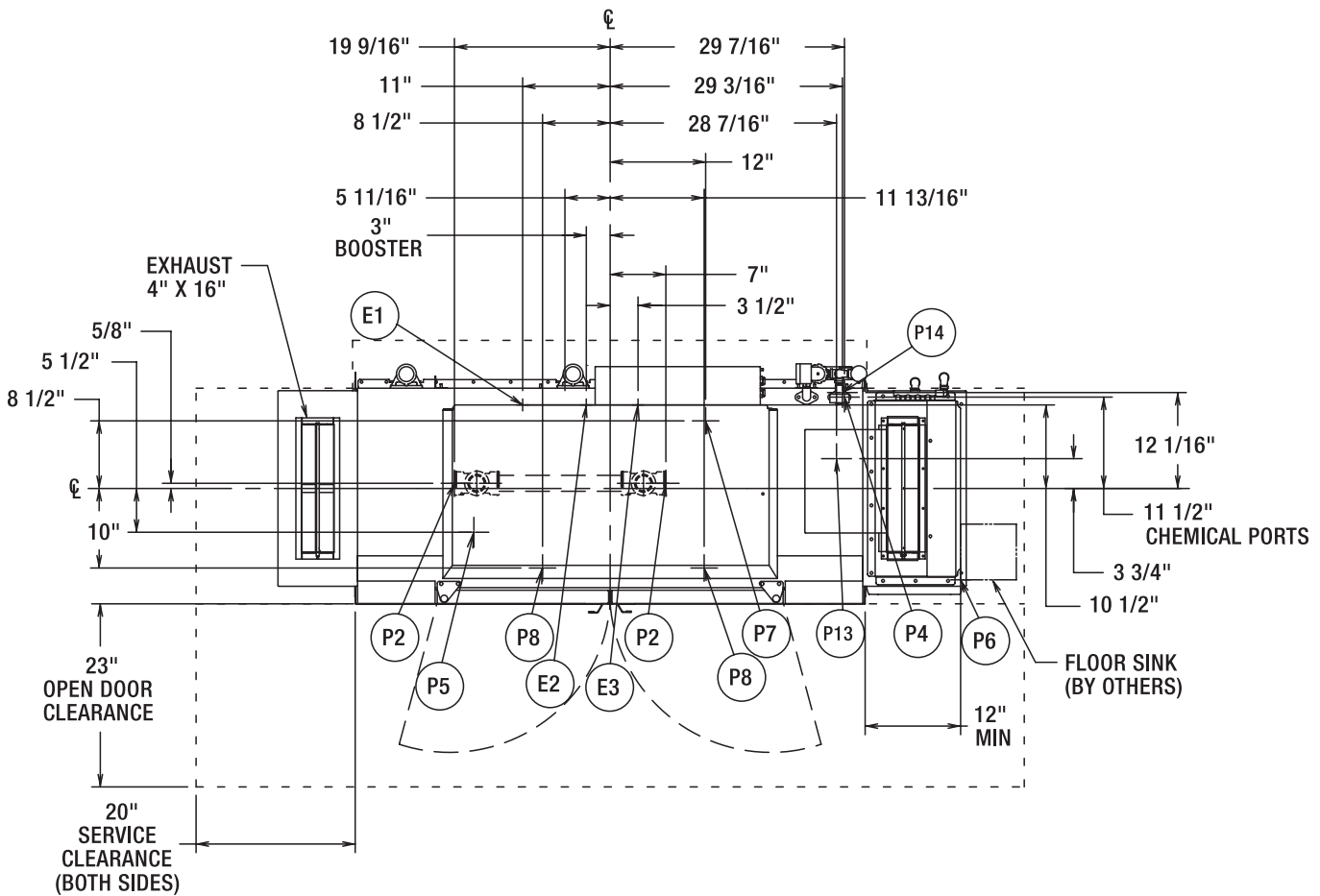

MISCELLANEOUS NOTES:

OPTIONAL VENT HOOD OR EXTENDED HOOD EXHAUST REQUIREMENTS: 200 CFM ENTRANCE END.
ALL DIMENSIONS TAKEN FROM FLOOR LINE MAY BE INCREASED APPROXIMATELY 3/4" OR DECREASED 1/2".
64" INSIDE TANK (AT TABLE CONNECTION)
63-25/32" TABLE TO TABLE.
NET WEIGHT OF MACHINE: 794 LBS (STD HEIGHT), DOMESTIC SHIPPING WEIGHT: 970 LBS (STD HEIGHT).
REQUIRES A BACKDRAFT DAMPER IN THE VENTILATION SYSTEM. (TO BE SUPPLIED AND INSTALLED BY OTHERS)

SERVICE CONNECTION FOR MOTORS AND CONTROLS

MOTORS: 1/6 HP CONVEYOR 2 HP WASH			
VOLTAGE	RATED AMPS	MINIMUM SUPPLY CIRCUIT CONDUCTOR AMPACITY	MAXIMUM PROTECTIVE DEVICE
200-240/50/3	17.5	25	25
208-240/60/3	19.4	25	25
380-415/50/3	10.6	15	15
380/60/3	12.8	20	20
480/60/3	10.8	15	15
600/60/3	9.5	15	15

PLUMBING NOTES:

ELECTRIC, STEAM, AND GAS HEATS

WATER HAMMER ARRESTOR (MEETING ASSE-1010 STANDARD OR EQUIVALENT) TO BE SUPPLIED (BY OTHERS) IN HOT AND COLD WATER SUPPLY LINES AT SERVICE CONNECTIONS.

RECOMMENDED WATER HARDNESS TO BE 3 GRAINS OR LESS FOR BEST RESULTS.

RECOMMENDED BUILDING FLOWING HOT AND COLD WATER PRESSURE TO THE DISHWASHER IS 20 PSI, (15 PSI MIN - 25 PSI MAX).

IF COLD WATER TEMPERATURE IS LESS THAN 55°F CONTACT SALES ENGINEERING.

FOR CONVENIENCE WHEN CLEANING, WATER TAP SHOULD BE INSTALLED NEAR MACHINE WITH HEAVY DUTY HOSE AND SQUEEZE VALVE.

WHEN USED, CHEMICAL SANITIZING FEEDER MUST BE CERTIFIED TO NSF STANDARD 29.

STEAM HEAT ONLY

FLOWING STEAM PRESSURES ABOVE 50 PSI MUST HAVE A PRESSURE REGULATOR (BY OTHERS) INSTALLED IN THE STEAM LINE.

SHUT OFF VALVE MUST BE SUPPLIED (BY OTHERS) IN THE STEAM LINE TO THE DISHWASHER.



701 S Ridge Avenue, Troy, OH 45374
1-888-4HOBART • www.hobartcorp.com

CL64eR *advansys* STEAM R-L

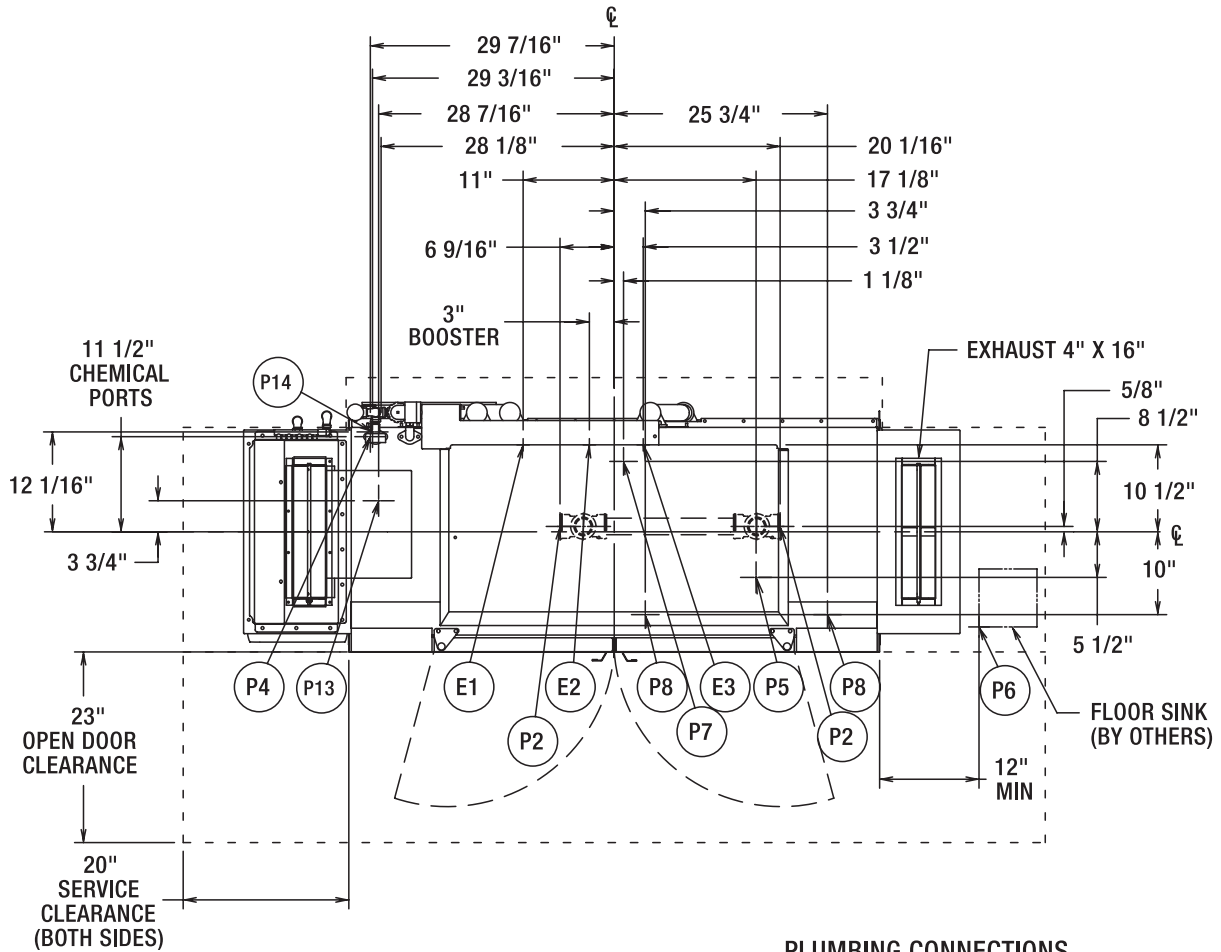

ELECTRICAL CONNECTIONS

CONNECTION INFORMATION
(AFF = ABOVE FINISHED FLOOR)

LEGEND

ELECTRIC, STEAM, AND GAS HEATS

- E1 ELECTRIC CONNECTION: SINGLE POINT, ELEC, GAS, & STEAM, 1-1/4" CONDUIT HOLE OR 2" CONDUIT, 63-3/4" AFF
- E2 ELECTRIC CONNECTION: BOOSTER. 30KW, 1-1/4" CONDUIT HOLE OR 2" CONDUIT HOLE, 63-3/4" AFF
- E3 ELECTRIC CONNECTION: DETERGENT AND RINSE FEEDERS. 1/2" CONDUIT. 64-1/4" AFF

PLUMBING CONNECTIONS

CONNECTION INFORMATION
(AFF = ABOVE FINISHED FLOOR)

LEGEND

ELECTRIC, STEAM, AND GAS HEATS

- P2 DRAIN: 2" FPT, 7-3/8" AFF TWO POSSIBLE CONNECTIONS; MAY BE DRAINED TO EITHER SIDE OF VALVE, PLUG OPPOSITE SIDE.
- P4 RINSE FEEDER: REMOVE 1/8" NPT PIPE PLUG TO ACCESS TAPPED HOLE. 1/8" NPT 59-9/16" AFF.
- P5 DETERGENT PROBE SENSOR: REMOVE CAP AND STUD ASSEMBLY TO ACCESS 7/8" DIA HOLE (WASH TANK ONLY). 14-5/8" AFF.
- P6 INDIRECT DRAIN-FLOOR SINK: BY OTHERS. 0" AFF. WHEN REQUIRED, INSTALL FLOOR SINK OUTSIDE THE PERIMETER OF THE DISHWASHER.
- P13 HOT WATER CONNECTION: 1/2" FPT, 11-3/16" AFF. HIGH TEMP. W/30K BOOSTER 110°F MIN.
- P14 COLD WATER CONNECTION: 1/2" FPT, 14-3/8" AFF. COLD TEMP. 55°F MIN

STEAM HEAT ONLY

- P7 STEAM COILS: 10 TO 50 PSI FLOWING, 1" FPT, 8-3/8" AFF.
- P8 CONDENSATE RETURN: A 10 PSI MINIMUM DIFFERENTIAL PRESSURE ACROSS THE STEAM TRAP MUST BE MAINTAINED. 3/4" FPT. 11-1/8" AFF TWO CONNECTIONS. (TWO BUCKET TYPE TRAPS FURNISHED).

CL64eR advansys DISHWASHER

HOBART701 S Ridge Avenue, Troy, OH 45374
1-888-4HOBART • www.hobartcorp.com

SPECIFICATIONS: Meets requirements of A.S.S.E. Standard No. 1004.

DESIGN: Semi automatic, high temperature double-tank, rack-type dishwasher with flexible thermal layer curtains at the ends of chamber and between wash, rinse and final rinse zones. Insulated hinged inspection doors located in front of machine provide easy access to wash arms, rinse arms, strainer, strainer basket, and pump intake screen. Length of machine inside tank (at table connection) 64". Machine designed to clean and sanitize with hot water 160°F wash, 160° power rinse and 180°F (minimum) final rinse. Water hardness recommended to be 3 gr. for best results. Automatic interlocks shut off pump and conveyor if door is opened when machine is in operation.

CONSTRUCTION: Tank, chamber, frame, legs, control box, doors, and all panels are constructed of stainless steel.

PUMP: Two 165 gpm recirculating stainless steel pumps and impeller with a ceramic seat seal. Easily accessible pumps assembly permits quick inspection. The pumps are self-draining. All piping distributing water to the upper and lower wash arms is stainless steel tubing.

PUMP MOTOR: Built for Hobart 2 hp grease-packed ball bearings, splash proof, ventilated with manual, resettable inherent overload protection. Available in electrical specifications of 208-240/60/3, 480/60/3 and 600/60/3. Also available, but not submitted for UL listing are 200-240/50/3 and 380-415/50/3.

ENERGY RECOVERY COIL: The condensing system using a tube and fin coil constructed of copper and corrosion resistant aluminum.

CONTROLS: A stainless steel control module with power and "start/stop" buttons is mounted on top of the machine. Machine control circuitry will be operated from a 120-volt control circuit transformer. Electrical components are completely wired with 105°C, 600V thermoplastic insulated wire with stranded conductors routed through UL listed electrical conduit or covered wire way.

CONVEYOR: Rapid Return drive, designed for more even throughput of racks and allows for an 18.75-inch separation between the wash and the rinse zone. Racks conveyed automatically through wash and rinse zones. Ball Detent Clutch drive prevents damage to machine or racks, should movement of racks be obstructed. Conveyor speed: 9.5 FPM.

DRIVE MOTOR: Built for Hobart, 1/2 horsepower gear motor, ventilated with manual, resettable inherent overload protection. Available in electrical specifications of 208-240/60/3, 480/60/3 and 600/60/3. Also available, but not submitted for UL Listing are 200-240/50/3 and 380-415/50/3.

POWER WASH AND RINSE: Wash and rinse tanks are equipped with upper and lower stainless steel CFD Wash Arms which effectively direct water jets to all ware surfaces. Both upper and lower wash arms are self-aligning and have easily removable end caps for cleaning without use of tools. A removable perforated stainless steel strainer pan supports a deep perforated stainless steel basket.

FINAL RINSE: Final rinse flow rate: 2.2 gpm, .39 gpr, 132-gph. Stainless steel upper and lower Auto Position Rinse Arms™

have single rows of nozzles. Racks entering the rinse zone automatically trigger rinse. Final rinse water line is equipped with a vacuum breaker downstream of an electrically operated solenoid valve in common piping system. Rinse agent dispenser injection ports provided in final rinse piping above chamber.

FILL: Fill water line is equipped with vacuum breaker on downstream side of electrically operated solenoid valve in common piping system, for automatic maintenance of tank level.

DRAIN AND OVERFLOW: Large bell-type automatic overflow and drain valve controlled from inside of machine. Drain automatically seats by closing inspection doors. Drain housing can be plumbed from load or unload end of machine.

STANDARD EQUIPMENT: Energy Recovery, Digital display of wash and final rinse temperature. Positive low water protection for tank heat. Thermal Layered Curtains throughout machine are keyed to ensure proper placement. Drain is automatically closed when inspection doors are closed. Stainless steel adjustable feet. Bolted stainless steel enclosure panels around perimeter and underneath machine. Automatic tank fill. Door interlock. Auto-timer. Vent fan and booster heater controls. Low temperature alerts. Service diagnostics. Dirty water indicator. Delime notification. Conveyor dwell. Energy Saver Mode. NAFEM Data Protocol compliant. Pressure regulating valve. Booster heater (30 kw).

WASH TANK HEATING SELECTIONS (must choose one):

ELECTRIC: Two electric Incoloy® sheathed immersion heaters (15 KW and 10 KW) removable from inside tank. Tank water temperature is controlled by microprocessor controlled thermostat with positive low-water protection and magnetic contactor. (Disconnect switches not furnished.) A high limit device mounted on the surface of the tank additionally protects heating element.

STEAM: One-inch stainless steel steam coil. Tank water temperature controlled by microprocessor controlled thermostat with positive low-water protection. Steam supplied to machine through high temperature steam solenoid valve and line strainer.

GAS: Regulated infrared immersion tube gas burner system. Microprocessor controlled thermostat and a blower with a pressure switch control tank water temperature. Positive low water protection is provided. A high limit device mounted on the surface of the tube additionally protects immersion tube. A solid-state igniter board controls the gas valve and provides flame ignition. A transformer steps the control circuit voltage down from 120 volts to 24 volts to power the igniter board and gas valve. For natural gas, gas pressure to burner (customer connection) not to exceed 7" W.C. For LP gas, gas pressure to burner (customer connection) not to exceed 11" W.C. If gas pressure is higher than 7" W.C. natural or 11" W.C. LP pressure regulating valve must be supplied (by others) in the gas line to the dishwasher.

OPTIONAL EQUIPMENT AT EXTRA COST:

Stainless steel vent hoods with vent stack, and locking-type damper (load end only). Canopy exhaust power vent kit. Higher than standard chamber. Side loaders and unloaders. 19¾" x 19¾" peg, combination and miscellaneous racks. Table limit switch. Drain water-tempering kit.

As continued product improvement is a policy of Hobart, specifications are subject to change without notice.